

SHARKY FS 473

ULTRASONIC FLOW SENSOR

DIEHL
Metering



APPLICATION

The ultrasonic flow sensor can be used for flow measuring in local and district heating / cooling systems.

FEATURES

- ▶ Dynamic range (DR) of up to 1:250 ($q_i:q_p$) in class 2 (depends on meter size), standard 1:100
- ▶ Extreme low power consumption --> longer battery lifetime
- ▶ Approved according EN 1434 and MID in class 2 and 3 and PTB K 7.2 (cooling)
- ▶ High long term stability
- ▶ Applicable for different calculators with impulse input
- ▶ Continuous time-correct pulses - no pulse packages
- ▶ Free selectable impulse values
- ▶ The temperature range depending on the application up to 5 ... 150 °C
- ▶ Battery or external power supply
- ▶ Specific housing for falling and rising pipes

SHARKY FS 473

ULTRASONIC FLOW SENSOR

GENERAL

SHARKY FS 473	
Application	Heating - cooling
Approval	MID (DE-07-MI004-PTB022) and PTB K 7.2 for cooling (22.76/10.01)
Ambient class	EN 1434 class C / MID class E2 + M2
Ambient temperature	°C 5 ... 55 (<35 °C have a positive lifetime effect)
Battery supply	3.0 VDC battery - up to 12 years lifetime
External supply	3.0 ... 5.5 VDC
Mounting position	Any position
Protection class	Heating: IP 54; heating potted: IP 65; cooling: IP 65
Interfaces	Open Collector pulse output ¹ - output for testing and communication ²
Volume pulse value ³	10 ml ... 5000 l/pulse (depending on sensor sizes and supply)
Cable length of impulse cable	2.4 m (4.9 or 9.9 m optional)
Material of the flow sensor body	Brass (q _p 0.6 ... 100 m ³ /h), spheroidal cast iron (q _p 15 ... 100 m ³ /h)

¹ The pulse output can be chosen without galvanic isolation (standard) or with galvanic isolation (only with battery supply). The flow sensor has by default a 4-wire impulse cable.

² The flow sensor can either emit a high resolution test pulse (standard) or communicate via the same output. By using an adapter the flow sensor can be read via the HYDRO-SET software.

³ The pulse duration is between 1 and 250 ms. It depends on the pulse value and on the nominal flow rate q_p.
Standard pulse values: 1, 2.5, 10, 25, 100, 250 l/pulse

REACH

Information pursuant to Article 33 (1) of Regulation (EC) No 1907/2006 of the European Parliament and of the Council of 18 December 2006:

This product series contains components with the following substances in a concentration of more than 0.1% weight by weight (w/w):

- Lead (CAS no.: 7439-92-1)
- Lead titanium zirconium oxide (CAS no.: 12626-81-2)
- 1,2-dimethoxyethane (CAS no.: 110-71-4)

TEMPERATURE RANGE

SHARKY FS 473	
Temperature range heating - battery supplied	°C 5 ... 90 / 5 ... 105 ¹
Temperature range heating - external supplied	°C 5 ... 105 / 130 / 150 (depends on meter size and material)
Temperature range cooling - battery supplied / external supplied	°C 5 ... 50 / 5 ... 90

¹ Only in rising or falling pipes or tilted horizontal installation

SHARKY FS 473

ULTRASONIC FLOW SENSOR

TECHNICAL DATA

Nominal flow rate	q_p	m^3/h	0.6	1.5	1.5	2.5	6	6	6
Nominal diameter	DN	mm	15	15	20	20	25	32	40
Overall length	L	mm	110	110	130	130	260	260	150
Starting flow rate		l/h	1	2.5	2.5	4	10	10	10
Minimum flow rate (DR 1:250)	q_i	l/h	6	6	6	10	24	24	-
Minimum flow rate (DR 1:100)	q_i	l/h	6	15	15	25	60	60	60
Minimum flow rate (up side down installation)	q_i	l/h	6	6	6	10	24	24	
Maximum flow rate	q_s	m^3/h	1.2	3	3	5	12	12	12
Overload flow rate		m^3/h	2.5	4.6	4.6	6.7	18.4	18.4	18.4
Pressure loss at q_p	Δp	mbar	95	120	75	100	128	128	190
Temp. range heating - brass body		$^{\circ}C$	5 ... 130	5 ... 130	5 ... 130	5 ... 130	5 ... 150	5 ... 150	5 ... 150
Temp. range heating - spheroidal cast iron body / brass PN 40		$^{\circ}C$	-	-	-	-	-	-	-
kv value ($q_p^2 (m^3/h) = kv^2 \times \Delta p$ (bar))			1.95	4.33	5.48	7.91	16.77	16.77	13.76
Nominal flow rate	q_p	m^3/h	10	15	25	40	60	100	
Nominal diameter	DN	mm	40	50	65	80	100	100	
Overall length	L	mm	300	270	300	300	360	360	
Starting flow rate		l/h	20	40	50	80	120	120	
Minimum flow rate (DR 1:250)	q_i	l/h	40 ¹	60 ¹	100 ¹	160 ¹	240 ¹	400 ¹	
Minimum flow rate (DR 1:100)	q_i	l/h	100	150	250	400	600/1200 ²	1000/1200 ²	
Minimum flow rate (up side down installation)	q_i	l/h	100	150	250	400	1200	1200	
Maximum flow rate	q_s	m^3/h	20	30	50	80	120	120	
Overload flow rate		m^3/h	24	36	60	90	132	132	
Pressure loss at q_p	Δp	mbar	140	140	75	80	75	210	
Temp. range heating - brass body		$^{\circ}C$	5 ... 150	5 ... 150	5 ... 150	5 ... 150	5 ... 150	5 ... 150	
Temp. range heating - spheroidal cast iron body / brass PN 40		$^{\circ}C$	-	5 ... 105	5 ... 105	5 ... 105	5 ... 105	5 ... 105	
kv value ($q_p^2 (m^3/h) = kv^2 \times \Delta p$ (bar))			26.73	40.09	91.29	141.42	219.09	218.22	

¹ Valid for horizontal installation only

² Up side down installation

SHARKY FS 473

ULTRASONIC FLOW SENSOR

DIMENSIONS THREAD VERSION

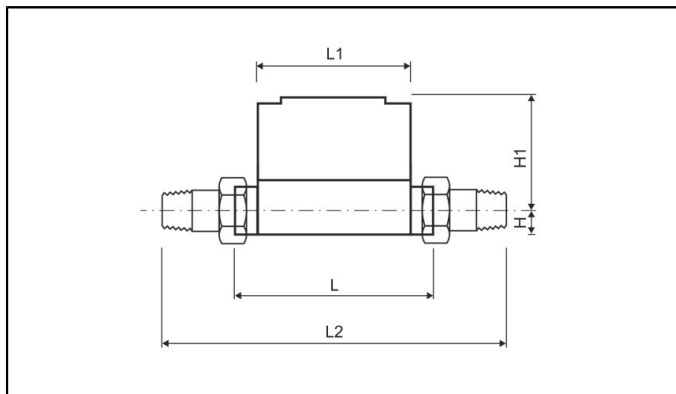

Nominal flow rate	q _p	m ³ /h	0.6	1.5	1.5	2.5	6	6	6
Nominal diameter	DN	mm	15	15	20	20	25	32	40
Overall length	L	mm	110	110	130	130	260	260	150
Overall length with coupling	L2	mm	190	190	230	230	380	380	-
Height	H	mm	14.5	14.5	18	18	23	23	33
Height	H1	mm	54.5	54.5	56.5	56.5	61	61	61
Length of electronic	L1	mm	90	90	90	90	90	90	90
Width of electronic	B	mm	65.5	65.5	65.5	65.5	65.5	65.5	65.5
Connection thread on meter		Inch	G ³ / ₄ B	G ³ / ₄ B	G1B	G1B	G1 ¹ / ₄ B	G1 ¹ / ₂ B	G2B
Connection thread of coupling		Inch	R ¹ / ₂	R ¹ / ₂	R ³ / ₄	R ³ / ₄	R1	R1 ¹ / ₄	R1 ¹ / ₂
Operating pressure	PN	bar	16/25	16/25	16/25	16/25	16/25	16/25	16/25
Weight		kg	0.6	0.6	0.61	0.61	1.35	1.35	1.52

Nominal flow rate	q _p	m ³ /h	10	15	25	40	60	100
Nominal diameter	DN	mm	40	50	65	80	100	100
Overall length	L	mm	300	270	300	300	360	360
Overall length with coupling	L2	mm	440	-	-	-	-	-
Height	H	mm	33	-	-	-	-	-
Height	H1	mm	66.5	-	-	-	-	-
Length of electronic	L1	mm	90	-	-	-	-	-
Width of electronic	B	mm	65.5	-	-	-	-	-
Connection thread on meter		Inch	G2B	-	-	-	-	-
Connection thread of coupling		Inch	R1 ¹ / ₂	-	-	-	-	-
Operating pressure	PN	bar	16/25	-	-	-	-	-
Weight		kg	2.6	-	-	-	-	-

SHARKY FS 473

ULTRASONIC FLOW SENSOR

DIMENSIONS FLANGE VERSION

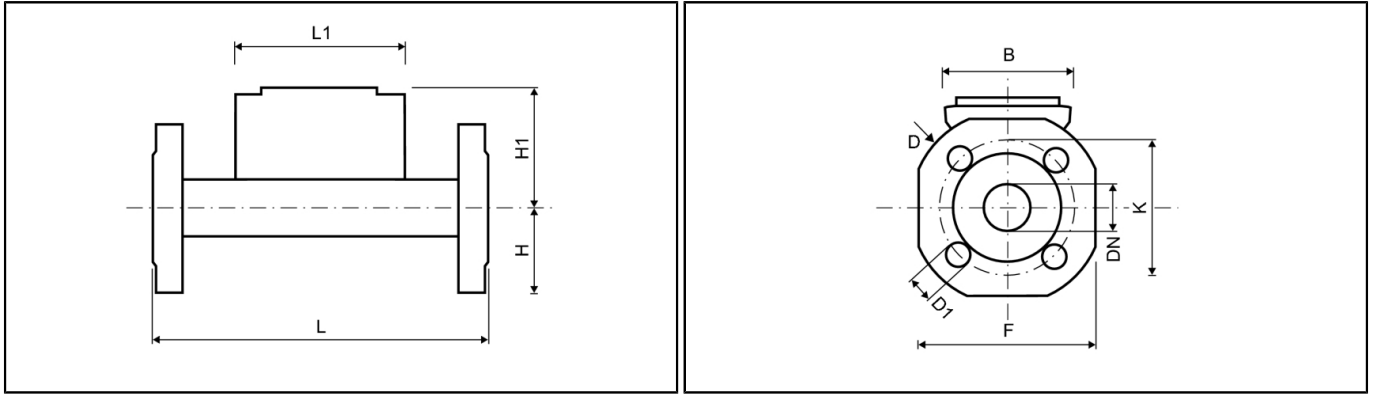

Nominal flow rate	q _p	m ³ /h	0.6	1.5	1.5	2.5	6	6	6
Nominal diameter	DN	mm	15	15	20	20	25	32	40
Overall length	L	mm	110	110	130	130	260	260	150
Height	H	mm	-	-	-	-	50	62.5	-
Height	H1	mm	-	-	-	-	61	61	-
Length of electronic	L1	mm	-	-	-	-	90	90	-
Width of electronic	B	mm	-	-	-	-	65.5	65.5	-
Flange dimension	F	mm	-	-	-	-	100	125	-
Flange diameter	D	mm	-	-	-	-	114	139	-
Hole circle diameter	K	mm	-	-	-	-	85	100	-
Screw hole diameter	D1	mm	-	-	-	-	14	18	-
Operating pressure	PN	bar	-	-	-	-	16/25/40 ³	16/25/40 ³	-
Number of screwholes		pcs	-	-	-	-	4	4	-
Weight brass body ²		kg	-	-	-	-	3.35	4.65	-
Weight spheroidal cast iron body ²		kg	-	-	-	-	-	-	-
Nominal flow rate	q _p	m ³ /h	10	15	25	40	60	100	
Nominal diameter	DN	mm	40	50	65	80	100	100	
Overall length	L	mm	300	270	300	300	360	360	
Height	H	mm	69	73.5	85	92.5	108	108	
Height	H1	mm	66.5	71.5	79	86.5	96.5	95.5	
Length of electronic	L1	mm	90	90	90	90	90	90	
Width of electronic	B	mm	65.5	65.5	65.5	65.5	65.5	65.5	
Flange dimension	F	mm	138	147	170	185	216	216	
Flange diameter	D	mm	148	163	184	200	235	235	
Hole circle diameter	K	mm	110	125	145	160	180 ¹ / 190	180 ¹ / 190	
Screw hole diameter	D1	mm	18	19	19	19	19 ¹ / 22	19 ¹ / 22	
Operating pressure	PN	bar	16/25/40 ³	16/25/40 ³	16/25	16/25/40 ³	16/25	16/25	
Number of screwholes		pcs	4	4	8	8	8	8	
Weight brass body ²		kg	6.6	7.45	9.45	11.1	16.9	16.9	
Weight spheroidal cast iron body ²		kg	-	6.31	8.08	10.01	15.76	15.75	

¹ Values for PN 16 housing

² Meter with battery and 2.4 m cable length of the pulse cable

³ Only up to 105 °C

SHARKY FS 473

ULTRASONIC FLOW SENSOR

PRESSURE LOSS GRAPH / TYPICAL ERROR GRAPH

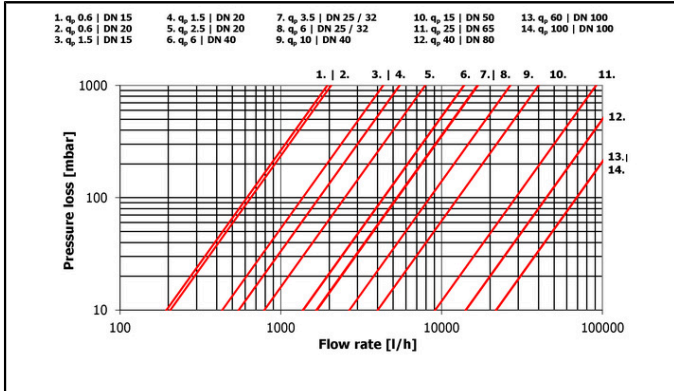

Pressure loss graph

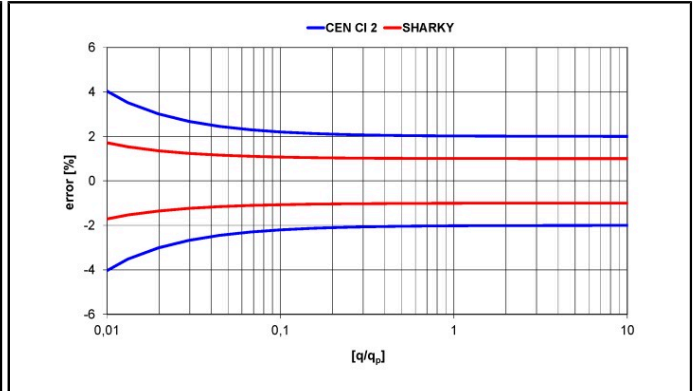

Typical error graph