

# PROMAG

ELECTROMAGNETIC FLOW SENSOR

**DIEHL**  
Metering



## APPLICATION

The electromagnetic flowmeter PROMAG designed for measuring heating water or any other type of conductive liquids used in air conditioning systems. It is characterized by high measuring accuracy and extended measuring range. Free of any moving parts, PROMAG offers a wide range of original technical solutions to suit various applications, such as glycol water measurement at  $-40^{\circ}\text{C}$  to overheated water at  $+130^{\circ}\text{C}$ .

Combined with a CALEC ST III or SCYLAR INT 8 calculator, PROMAG is, all year round, the ideal hydraulic part of energy measurement.

## FEATURES

- ▶ All liquids measurement with a conductivity  $> 5 \mu\text{S}/\text{cm}$
- ▶ No mechanical moving part
- ▶ Process temperature range:  $-40^{\circ}\text{C}$  to  $+130^{\circ}\text{C}$
- ▶ Very low pressure drop
- ▶ Pulse output and analogue output 4 ... 20 mA
- ▶ Bluetooth configuration

# PROMAG

## ELECTROMAGNETIC FLOW SENSOR

### GENERAL

PROMAG	
Application	Heating / cooling (without commercial transaction)
Measuring accuracy	% +/- 0.5
Ambient temperature	°C -20 ... +60
Power supply	100 to 240 V AC ; ± 10%   50 to 60 Hz ; ±5 Hz
Mounting position	Any position
Degree of protection	IP67
Pulse output	Adjustable pulse width: 0.05 ... 2,000 ms
Current output	4 ... 20 mA
Status output	Error message or flow direction recognition
Minimal conductivity	µS/cm 5
Power consumption	200 mA max
Galvanic isolation	All circuits for inputs, outputs and power supply are galvanically insulated from each other
EMC compatibility	According to EN61326 and NAMUR NE21
Drinking water certification	ACS for PROMAG W 10
Parameters adjustment	On display or Bluetooth with the SmartBlue application for Android

### TECHNICAL DATA FLOW SENSOR

Nominal diameter	DN	mm	25	32	40	50	65	80	100	125
Maximal flowrate	q <sub>s</sub>	m <sup>3</sup> /h	18	30	42	66	120	180	282	450
Minimal flowrate	q <sub>i</sub>	m <sup>3</sup> /h	0.54	0.9	1.5	2.1	3.6	5.4	8.7	13.2
Pulse weight		l/pulse	1	1	1	1	10	10	10	100

Nominal diameter	DN	mm	150	200	250	300	350	400	500
Maximal flowrate	q <sub>s</sub>	m <sup>3</sup> /h	600	1,100	1,700	2,400	3,300	4,200	6,600
Minimal flowrate	q <sub>i</sub>	m <sup>3</sup> /h	20	35	55	80	110	140	220
Pulse weight		l/pulse	100	100	100	100	100	1,000	1,000

### COLD APPLICATION (PROMAG W 10) ACS CERTIFIED

Nominal diameter	DN	mm	25	32	40	50	65	80	100	125
Polyurethane coating - T. -20°C to +50°C - compact version	PN	bar	40	40	40	40	16	16	16	16

Nominal diameter	DN	mm	150	200	250	300	350	400	500
Polyurethane coating - T. -20°C to +50°C - compact version	PN	bar	16	10	10	10	10	10	10

### AMBIANT APPLICATION (PROMAG P 10)

Nominal diameter	DN	mm	25	32	40	50	65	80	100	125
Polyurethane coating - T. -20°C to +110°C - compact version	PN	bar	16	16	16	16	16	16	-	16

Nominal diameter	DN	mm	150	200	250	300	350	400	500
Polyurethane coating - T. -20°C to +110°C - compact version	PN	bar	16	10	10	10	-	-	-

### HOT APPLICATION (PROMAG P 10)

Nominal diameter	DN	mm	25	32	40	50	65	80	100	125
Polyurethane coating - T. -40°C to +130°C - compact version	PN	bar	16	16	16	16	16	16	16	16

Nominal diameter	DN	mm	150	200	250	300	350	400	500
Polyurethane coating - T. -40°C to +130°C - compact version	PN	bar	16	10	10	10	10	10	10

Diehl Metering S.A.S. - Head Office - 67 rue du Rhône - BP 10160 - FR-68304 Saint-Louis Cedex - Phone: + 33 (0)3 89 69 54 00 - Fax: + 33 (0)3 89 69 72 20 - metering-France-info@diehl.com - www.diehl.com/metering  
 International Sales - 67 rue du Rhône - BP 10160 - FR-68304 Saint-Louis Cedex - Phone: + 33 (0)3 89 69 54 21 - Fax: + 33 (0)3 89 69 54 22 - metering-France-export@diehl.com  
 Subject to technical adjustments.

# PROMAG

## ELECTROMAGNETIC FLOW SENSOR

### PROMAG W 10 : DIMENSIONS, WEIGHT AND CONNECTIONS

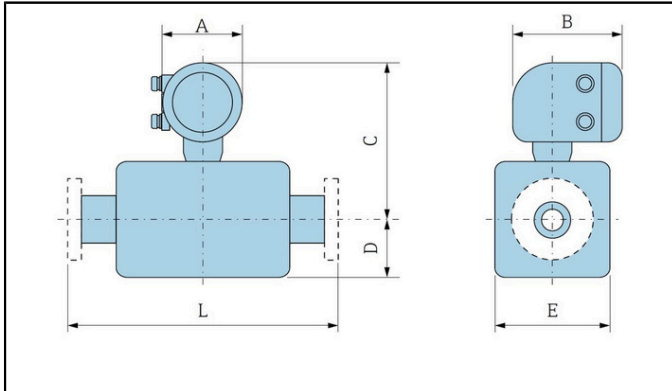

Compact version

PROMAG W 10 : Flange connection EN1092-1 (DIN 2501) (DN25 PN16 only according to EN1092-1)

Nominal diameter	DN	mm	25	32	40	50	65	80	100	125
L		mm	200	200	200	200	200	200	250	250
E		mm	120	120	120	120	180	180	180	260
B		mm	178	178	178	178	178	178	178	178
A		mm	139	139	139	139	139	139	139	139
C		mm	258	258	258	258	283	283	283	323
D		mm	84	84	84	84	109	109	109	150
Weight		Kg	10	11	12	13	13	15	18	25

Nominal diameter	DN	mm	150	200	250	300	350	400	500
L		mm	300	350	450	500	550	600	650
E		mm	260	324	400	460	490	542	648
B		mm	178	178	178	178	178	178	178
A		mm	139	139	139	139	139	139	139
C		mm	323	348	373	398	457	483	490
D		mm	150	180	205	230	245	271	324
Weight		Kg	31	52	81	95	106	121	156

# PROMAG

## ELECTROMAGNETIC FLOW SENSOR

### PROMAG P 10 : DIMENSIONS, WEIGHT AND CONNECTIONS

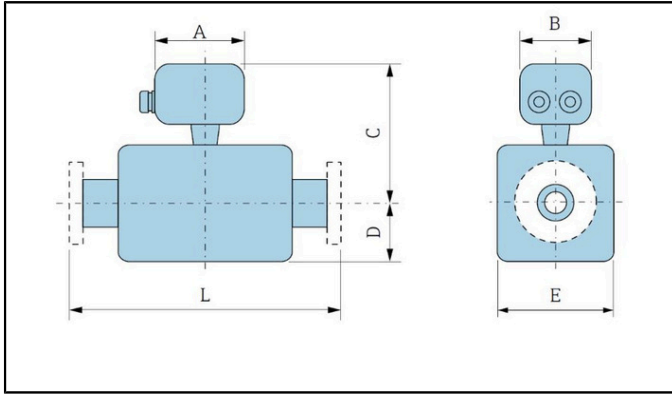

Compact version

Flange connection EN1092-1 (DIN 2501), DN ≤ 300 type A ; DN ≥ 350 type B (DN25 PN16 only according to EN1092-1)

Nominal diameter	DN	mm	25	32	40	50	65	80	100	125
L		mm	200	200	200	200	200	200	250	250
E		mm	120	120	120	120	180	180	180	260
B		mm	136	136	136	136	136	136	136	136
A		mm	148	148	148	148	148	148	148	148
C		mm	197	197	197	197	222	222	222	262
D		mm	84	84	84	84	109	109	109	150
Weight		Kg	8	8.7	10.1	11.3	12.7	14.7	16.7	22.2

Nominal diameter	DN	mm	150	200	250	300	350	400	500
L		mm	300	350	450	500	550	600	650
E		mm	260	324	400	460	564	616	717
B		mm	136	136	136	136	136	136	136
A		mm	148	148	148	148	148	148	148
C		mm	262	287	312	337	396	422	472
D		mm	113	180	205	230	282	308	359
Weight		Kg	26.2	45.7	65.7	70.7	105.7	120.7	156.7