

HYDRUS 2.0 BULK

ULTRASONIC METER



APPLICATION

HYDRUS 2.0 BULK is a static ultrasonic bulk water meter designed for applications of cold and hot water supply enabling accurate measuring with long-term stability under difficult conditions (no measurement of air and insensitive to sedimentation). Developed within the framework of the MID, it complies with the European regulations and holds sanitary conformity certificates (KTW/W270, ACS, WRAS and others). The integrated communication function supports meter data provision via mobile reading (walk-by/drive-by/passive drive-by) or fixed network (upgrade without on-site configuration). In combination with Diehl Metering's IZAR fixed network system, which stands out with extra high coverage and strong performance to reach hard-to-read locations, high data granularity and timeliness will be maintained. This is what makes it a high responsive infrastructure to take actions immediately.

FEATURES

- DN 50 to 200
- MID approved with dynamic range up to R 1000
- IP 68 suitable for outdoor installations
- Integrated radio communication based on Open Metering telegram (OMS Generation 3 or 4, Profile B)
- Wired M-Bus/Pulse/Pulse, wireless M-Bus, wireless M-Bus in combination with wired L-Bus/Pulse interface
- Display with error and alarm codes including leakage detection and self-monitoring function
- Battery lifetime up to 16 years
- U0 / D0, no need for calming sections

TECHNICAL DATA

HYDRUS 2.0 BULK			
Medium temperature range	°C	+0.1 ... +50 (T30 / T50), +0.1 ... +90 (T90)	
Accuracy	Accuracy class 2 acc. to ISO 4064:2014 / OIML R49:2013		
Ambient operating temperature	°C	-10 ... +55	
Ambient storage temperature	°C	-10 ... +70 (>35 °C max. 4 weeks)	
Environmental class	O (Outdoors)		
Mechanical environmental class	M2		
Electromagnetic environmental class	E2		
Flow profile sensitivity class	U0/D0 (no calming sections required)		
Installation position	Horizontal, inclined 45°, inclined 90°, vertical		
Maximum admissible pressure	MAP	bar	16
Minimum operating pressure		bar	0.3
Pressure loss class	Δp	bar	0.16
Power supply	3.6 V lithium battery (D-cell)		
Battery lifetime ¹	Up to 16 years (all communication interfaces)		
Communication interfaces	Optical, OMS wireless M-Bus 434 or 868 MHz, M-Bus, L-Bus and Pulse		
Data storage	For errors, alarms and measuring values, data logging capabilities to record up to 512 daily +32 monthly values		
Protection class	IP 68		

¹ Depends on the sending interval of the radio telegram, the telegram length and the ambient temperature at the installation

TECHNICAL DATA DISPLAY

HYDRUS 2.0 BULK	
Display indication	LCD, 9-digit, additional symbols/display counter/unit
Units displayed DN 50 - 100	Volume (m ³ + 2 decimal places) and flow rate (m ³ /h + 3 decimal places)
Units displayed DN 125 - 200	Volume (m ³ + 1 decimal place) and flow rate (m ³ /h + 3 decimal places)
Values displayed	Display test - volume - battery lifetime - firmware version - software checksum - flow - current/continuous/historical error - alarm status - high resolution volume - due date - due date volume - reverse volume - display counter - low battery indication - leakage indication - metrological log access - radio signal ON/OFF - alarm indication - meter lock ON/OFF

INTERFACES - OVERVIEW

HYDRUS 2.0 BULK	
Optical	For switching the display loop
Radio	434 or 868 MHz, Open Metering Standard radio frame (R3) for mobile reading sent every 14 seconds, long range radio frame (R4) for fixed network sent every 5 minutes, extra long range radio frame (R4+) for fixed network sent every 15 minutes
M-Bus	2400 baud, cable length 5m, power supply only via built-in battery - is combined with two Pulse outputs
L-Bus	In combination with radio, cable length 5m (only one interface communicating at the same time)
Pulse (Open drain)	Two Pulse outputs, or one Pulse and one L-Bus output, Pulse cable length 5m

SECURITY

PRIVACY

The HYDRUS 2.0 BULK saves daily 512 consumption values. This data can be read locally and accessed only by using the IZAR@MOBILE 2. As a second logging, a small amount of 32 monthly consumption values can be stored. The HYDRUS 2.0 BULK

HYDRUS 2.0 BULK - ULTRASONIC METER

has a minimal sending interval of about 14 seconds and uses the OMS Generation 3 or 4, Profile B security level. Both, the radio protocol and the optical interface are encrypted by default.

VOLUME / PULSE OPEN DRAIN

HYDRUS 2.0 BULK		
Max. input voltage	V	30
Max. input current	mA	27
Max. voltage drop at active output	V/mA	2/27
Max. current through inactive output	µA/V	5/30
Max. reverse voltage without destroying outputs	V	6 (in case current does not exceed 27 mA)
Pulse rates DN 50	I/pulse	1 / 10 / 100 / 1000
Pulse rates DN 65 - 150	I/pulse	10 / 100 / 1000
Pulse output 1 variants	Total volume or forward volume	
Pulse output 2 variants	Flow direction or error, reverse volume	
Pulse frequency	Max. frequency 10 Hz	
Pulse width	50 ms	

POSSIBLE COMMUNICATION INTERFACES

HYDRUS 2.0 BULK	
Wireless M-Bus/Pulse/L-Bus	3 wire
M-Bus/Pulse/Pulse	5 wire
IZAR BE PULSE	4 wire

PERFORMANCE DATA - COLD WATER (T30 / T50) HORIZONTAL

Nominal diameter	DN	mm	50	65	80	100	125	150	200
Permanent flow rate	Q ₃	m ³ /h	25	40	63	100	160	250	400
Dynamic (Q ₃ /Q ₁)	R		800	800	800	800	800	800	800
Overload flow rate	Q ₄	m ³ /h	31.25	50	78.75	125	200	312.50	500
Transitional flow rate	Q ₂	l/h	50	80	126	200	320	500	800
Minimum flow rate	Q ₁	l/h	31.25	50	78.75	125	200	312.50	500
Starting flow rate		l/h	15	27	35	45	70	140	200
Pressure loss at Q ₃		bar	0.16	0.15	0.16	0.13	0.15	0.11	0.12
Pressure loss at Q ₄		bar	0.25	0.23	0.25	0.2	0.23	0.18	0.19
Maximum flow rate ²	Q _{high}	m ³ /h	54	87	134	250	400	625	1000
Flow coefficient	K _v	m ³ /h	63	105	158	280	420	747	1140

² Outlet pressure minimum 3 bar, maximum 100 hours per year, closed pipeline network

PERFORMANCE DATA - HOT WATER (T90) HORIZONTAL

Nominal diameter	DN	mm	50	65	80	100	125	150	200
Permanent flow rate	Q ₃	m ³ /h	25	40	63	100	-	-	-
Dynamic (Q ₃ /Q ₁)	R		400	400	400	400	-	-	-
Overload flow rate	Q ₄	m ³ /h	31.25	50	78.75	125	-	-	-
Transitional flow rate	Q ₂	l/h	100	160	250	400	-	-	-
Minimum flow rate	Q ₁	l/h	63	100	160	250	-	-	-
Starting flow rate		l/h	15	27	35	45	-	-	-
Pressure loss at Q ₃		bar	0.16	0.15	0.16	0.13	-	-	-
Pressure loss at Q ₄		bar	0.25	0.23	0.25	0.2	-	-	-
Flow coefficient	K _v	m ³ /h	63	105	158	280	-	-	-

APPROVAL

DN 50 - 200

Approval		MID DE-19-MI001-PTB011
Dynamic range (Q ₃ /Q ₁)	R	Up to 1000
Standards		ISO 4064, EN 14154, OIML R49
Sanitary conformity		KTW/W270, ACS, WRAS

DYNAMIC RANGE

DN 50 - 200

Q ₃ 25 ... 400 m ³ /h - T30	R	800
Q ₃ 25 ... 400 m ³ /h - T50	R	800H / 250V
Q ₃ 25 ... 100 m ³ /h - T90	R	400H / 160V

PRESSURE LOSS GRAPH / TYPICAL ERROR GRAPH

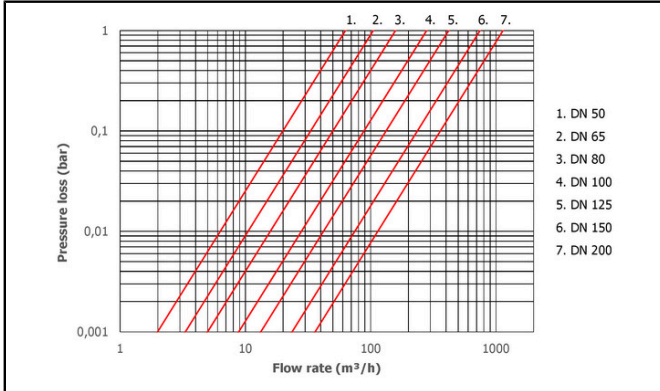

Pressure loss graph

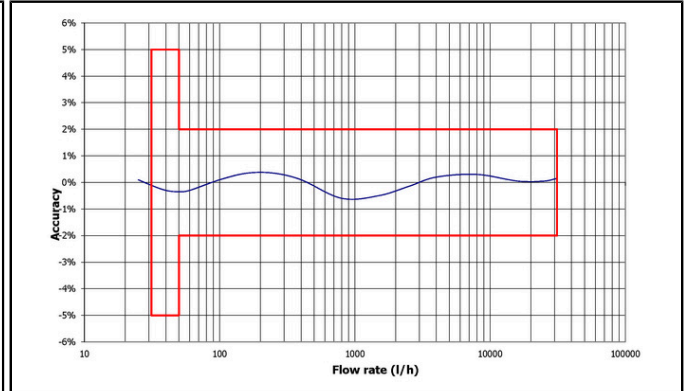

Typical error graph - Q₃ 25 m³/h

DIMENSIONS

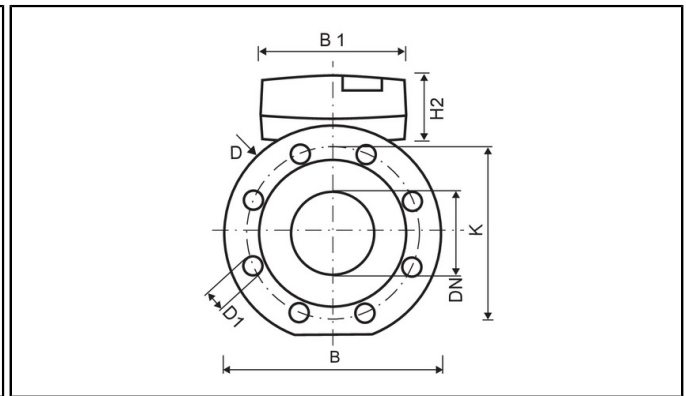
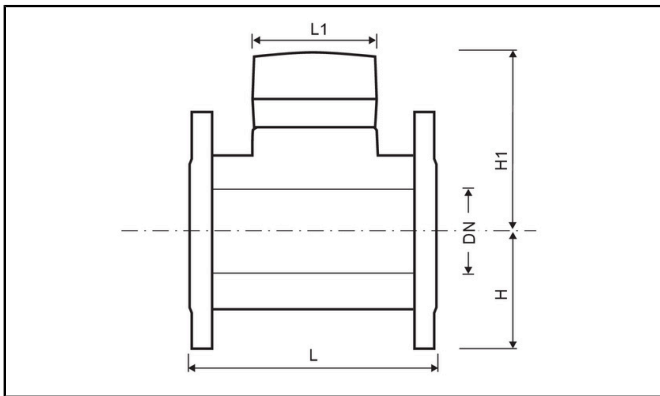

Nominal diameter	DN	mm	50	65	80	100	125	150	200	
			200 / 270 /		200 / 225 / 250 /					
Overall length (T30 / T50)	L	mm	300 ³	200 / 300 ³	300 / 350 ³	350 ⁴ / 360	250	300 / 500	350	
Overall length (T90)	L	mm	200	200	200 / 225	250	-	-	-	
Flange diameter ⁵	D	mm	165	185	200	220	250	285	340	
Hole circle diameter ⁵	K	mm	125	145	160	180	210	240	295	
Number of screwholes ⁵		pcs	4	4	8	8	8	8	12 ⁶	
Screwhole diameter ⁵	D1	mm	19	19	19	19	19	23	23	
Height	H	mm	74	87	95	105	120	135	161	
Height	H1	mm	121	143	147	165	177	185	215	
Height	H2	mm	61	61	61	61	61	61	61	
Counter length	L1	mm	98	98	98	98	98	98	98	
Meter width	B	mm	165	185	200	220	250	285	340	
Counter width	B1	mm	139	139	139	139	139	139	139	
Overall weight (approx.)		kg	7 / 9 / 9	8 / 11	11 / 13 /	14 / 15	17 / 19 / 20	23	38 / 45	51

³ Optionally with rotatable flange

⁴ Rotatable flange

⁵ Flanges according to EN 1092, PN 10/16

⁶ 8 Screwholes for PN 10

METER BODY VARIANTS

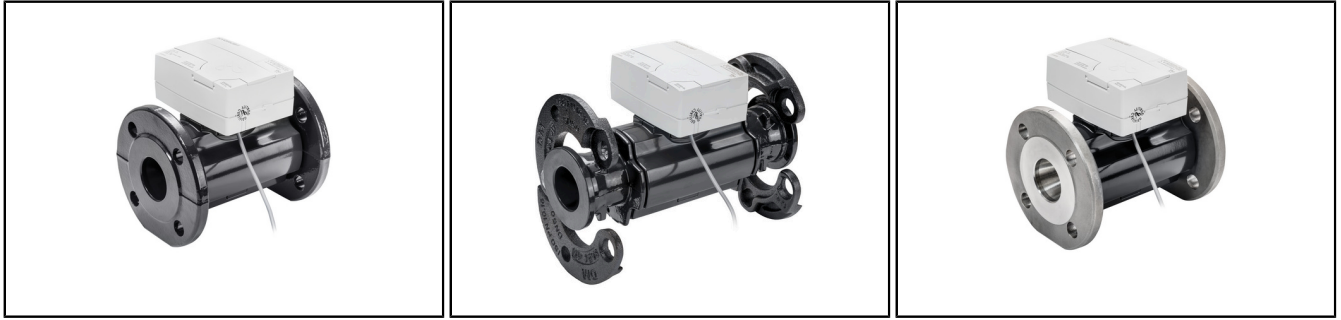

- a) The cold water meters come with an epoxy-coated cast iron housing as standard. ISO short length variants can optionally be manufactured with a stainless steel housing.
- b) ISO long length meters with diameters up to DN 100 can optionally come with rotatable flanges.
- c) Hot water meters are always provided with stainless steel housings (EN 1.4408, AISI 316).

REACH

Information pursuant to Article 33 (1) of Regulation (EC) No 1907/2006 of the European Parliament and of the Council of 18 December 2006:

This product series contains components with the following substances in a concentration of more than 0.1% weight by weight (w/w):

- Lead titanium zirconium oxide (CAS no.: 12626-81-2)

Economic Actor Information

Applicable regulation and legal obligations for products may change.

DIEHL METERING monitors applicable regulation to ensure their products comply at the date of placing on the market.

Each economic actor making products available on the market thereafter must independently keep informed about the current applicable regulation.

For questions, please contact: metering-germany-info@diehl.com

Diehl Metering (Jinan) Co., Ltd.
Building 11, Jinan Diya Shuangchuang Industrial Park
2566 Shijidadao
Licheng District, Jinan
Phone: +86 531 5882 0999
Fax: +86 531 5882 0998
metering-china-sales@diehl.com
www.diehl.com/metering

**EMPOWER A
SUSTAINABLE
FUTURE**