

**Stadtwerke Pirna**  
**From smart metering to smart city**  
**in a single solution**

Customer Case

85 m<sup>3</sup>

55 m<sup>3</sup>/h

27 231 m<sup>3</sup>/h





Stadtwerke **Pirna**

Stadtwerke Pirna provides water, district heating, electricity and gas to the city of Pirna (population 40,000) and its region in the east of Germany. To futureproof its water and district heating distribution networks and strengthen its smart city capabilities, the utility and service company partnered with Diehl Metering.

Through this collaboration, Stadtwerke Pirna was able to upgrade all its water and heat meters, while also planning and implementing an IoT network with optimal interoperability.



Driven by its ambitions in sustainability and smart city applications, Stadtwerke Pirna needed a solution with excellent interoperability.

## THE CHALLENGE: MODERNIZING METER READINGS AND PREPARING FOR FUTURE POSSIBILITIES

Founded 30 years ago, Stadtwerke Pirna has diversified to become a multi-utility service provider. Most recently, it has earned a reputation for innovation through initiatives such as its e-car sharing scheme, launched in 2021.

To modernize its water and district heating networks, Stadtwerke Pirna wanted to automate meter reading and make the most of the rich opportunities in IoT and intelligent monitoring. Before collaborating with Diehl Metering, meters were read manually using the traditional postcard method. This required consumers to read their own meters and send the figures to the utility by postcard or via the online customer portal. As well as being time-consuming, this method put the burden on the consumer and was subject to human error, often resulting in incorrect billing and customer complaints.

Inaccurate and incomplete data also made it impossible to explore key avenues of network optimization, such as leak detection in the water grid. In district heating, the main obstacle to achieving a more efficient network

was that data was only being read once a year.

To address these different challenges, Stadtwerke Pirna was looking for a turnkey solution to build an efficient Advanced Metering Infrastructure (AMI) and IoT network. This would allow it to fully automate readouts for all meters, as well as all sensors in its network, while benefiting from optimization opportunities and strengthening sustainability. Interoperability was particularly important to the utility, as it had wider ambitions in the future, including smart city applications.



## THE SOLUTION: A SINGLE SOURCE FOR NETWORK EFFICIENCY AND IoT OPPORTUNITIES

Diehl Metering worked with Stadtwerke Pirna to provide an all-in-one solution to address both its current network challenges and its future ambitions in IoT. This covered planning the IoT network, setting up the AMI, upgrading to ultrasonic heat and water meters, and supplying IZAR PLUS Portal for data management, analysis and insights. To address the utility's future ambitions, mioty® was integrated as a connectivity standard.

To uncover the full potential of its future IoT network, Stadtwerke Pirna chose to implement Diehl Metering's

IoT Network Planning Service. This three-step service consists of defining the goals and possibilities of the network so the right communication technology can be selected for long-term success. In the initial situation analysis, expert technicians presented Stadtwerke Pirna with the advantages and disadvantages of different technologies, independent of Diehl Metering's own solutions. This offered them a comprehensive understanding of the fundamentals for building a robust IoT network and business model. The second phase focused on planning the area to be covered by the radio

network and assessing locations for antennas. Finally, during execution planning, detailed designs mapped out the precise position of the antennas to optimize the network for the utility's current and future needs.

Following the IoT Network Planning Service, 12 antenna sites were identified over an area of 80km<sup>2</sup>, with more than 8,000 heat and water meters to be integrated. Over the next 6 years, the customer's current meters will be replaced by some 7,200 HYDRUS 2.0 meters for the water network and 1,200 SHARKY 775 heat

### IoT NETWORK PLANNING SERVICE

#### INITIAL IoT WORKSHOP

Learning about the pros and cons of different networks - and identifying the best-suited technologies for Stadtwerke Pirna's ambitions.

#### RADIO NETWORK PLANNING

Determining the area to be covered by the network, including antenna locations. Draft planning for heights and types of antenna to ensure optimal coverage.

#### EXECUTION PLANNING

Mapping out precise antenna locations and choosing the best types of antenna for current and future needs.

#### IoT NETWORK IMPL- EMENTATION SERVICE

Supporting the customer to set up its IoT network (IZAR radio & mioty®), including installation and commissioning of on-site antennas and data receivers, and the design and survey of the site.



**Diehl Metering supported Stadtwerke Pirna with every aspect of planning and implementing its IoT network, optimizing the solution for the utility's current and future needs.**

meters for the district heating network. Thanks to an integrated radio module, these ultrasonic meters are ready for automatic mobile reading immediately after installation.

Stadtwerke Pirna then decided to take advantage of Diehl Metering's IoT Network Implementation Service to set up its IoT network with expert support. Since interoperability is one of the customer's key priorities, the chosen communication technologies were IZAR radio for current use cases and mioty® for future applications. Diehl Metering's team helped the utility to install and commission its on-site antennas and data receivers to maximize their functionality. The IoT Network Implementation Service also included the design of the site and a site survey.

Thanks to the permanently-installed receivers, data is collected regularly, while the antennas are strategically positioned for cost-effectiveness and efficiency, ensuring that all data is reliably transmitted. All data is then automatically forwarded to the cloud-based Meter Data Management Software (MDM) IZAR PLUS Portal for monitoring, billing and analysis purposes.

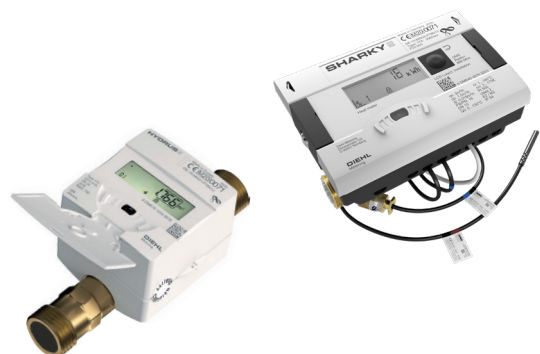

# THE BENEFITS: AN OPTIMIZED AND RELIABLE NETWORK BUILT FOR THE FUTURE

Thanks to Diehl Metering’s solution, Stadtwerke Pirna now has water and heat networks that answers its current challenges and opens up new possibilities for tomorrow.

Through the IoT Network Planning Service, the utility was able to plan the details of a fully compliant and future-proof network that is perfectly aligned with its need for smart metering, network optimization and smart city use cases, as well as its desire to be a provider of sustainable services. Diehl Metering’s guidance, consulting and training empowered Stadtwerke Pirna to confidently address key planning challenges like network coverage, budgeting and technical compatibility.

Relying on both expert advice and Diehl Metering’s innovative IoT Network Planning tool, the utility identified the most relevant communication technologies for its key priority of interoperability. While IZAR radio ensures the reliable and secure transmission of data for its current needs, mioty® opens up a new world of possibilities for the future. This software-based technology is a Low Power Area Network (LPWAN) that distinguishes itself from existing systems through high energy efficiency, mobility and scalability. Furthermore, it uses a patented telegram splitting technology to create an extremely high level of robustness against external and internal interference. The mioty® network will therefore allow Stadtwerke Pirna to seamlessly merge metering applications with the IoT world. The utility is particularly interested in exploring smart city uses such as

mobility (dynamic parking guidance systems, e-car sharing), energy (smart lighting) and the environment. In addition, the IoT Network Implementation Service has allowed the utility to minimize its business risk, since Diehl Metering builds the network and provides a warranty on the complete antenna build.

Diehl Metering and its partners ensured a fast and smooth installation of the antennas in places with good coverage, such as rooftops, chimneys and flagpoles, while taking into account static and wind load. Furthermore, the implementation uses the highest quality of antenna cables, with fastenings every 50 cm.

Finally, the automated meter readouts enabled by the HYDRUS 2.0 and SHARKY 775 meters allow the utility to deliver reliable billing, with end consumers only billed for their actual consumption as of the due date. The overall reading and transfer process is now much faster and more secure, and data can be analyzed and visualized in detail using IZAR PLUS Portal. In this way, Stadtwerke Pirna has a powerful tool for optimizing its district heating and water distribution networks, and detecting leaks within hours.



**THE IoT NETWORK** is specifically designed around Stadtwerke Pirna’s ambitions, enabling them to grow and develop as they want.



**WITH THE NEW AMI NETWORK** leaks can be detected within hours, rather than having to wait until the end of the year.



**THE MULTI-FACETED SOLUTION** comes with unrivalled interoperability and future-proofing – all from a single source.



**WITH mioty®** Stadtwerke Pirna can seamlessly merge metering applications with smart city applications such as dynamic parking guidance and smart lighting.

## UNIQUE TELEGRAM SPLITTING MULTIPLE ACCESS (TSMa) METHOD OF mioty®

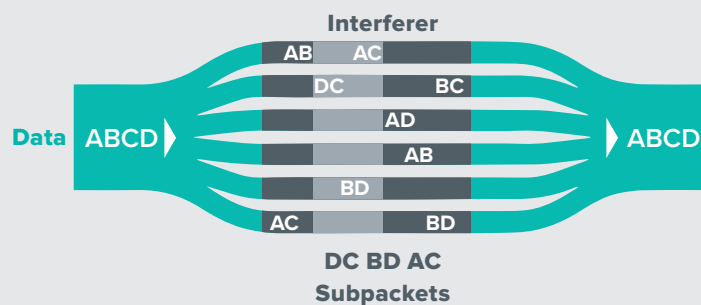



---

## ABOUT DIEHL METERING

Diehl Metering is a worldwide leader in the design, manufacture and supply of smart metering solutions. With over 150 years of experience, we empower utilities, municipalities and industries to take control of their infrastructures, bringing new efficiencies to the way they manage water and energy.

Our extensive range of services and solutions includes data-driven insights, IoT connectivity, fully-flexible software, and seamless intelligent metering. We also utilise artificial intelligence to boost performance and deliver cost savings for our customers.

Headquartered in Germany, we are a family-owned business with an international reach. We are proud to maintain our founding principles of quality, reliability and customer proximity while proactively shaping a better future for our customers and the communities they serve.

Our approach is to think global and act local.

By anticipating trends and remaining agile, we adapt and develop our strategy with our customers and for them.

In supporting their long-term growth, we also contribute to the sustainability of the planet, crafting innovations that enable our customers to make ever better use of the natural resources we all rely on.

