

ALTAIR MCI V5

ROTARY PISTON METER



APPLICATION

Domestic rotary piston water meter (only complete meter)

FEATURES

- Low noise level
- System compatibility, with standard applicable pulse output 1 l/pulse. ALTAIR MCI can be extended - with IZAR RADIO (radio module) or IZAR PULSE (pulse transmitter)
- Any mounting position + no calming sections necessary
- Low starting flow approximately 0.6 l/h permits recording of very small amounts of water
- Self-cleaning mechanism of measuring chamber
- Less exchange time as capsule and screw head is one part
- Self-cleaning mechanism of measuring chamber
- Encapsulated roller counter unit rotatable by 350°

METROLOGICAL DATA

Housing			Horizontal	Rising Pipe
Nominal diameter	DN	mm	20	20
Permanent flow rate	Q ₃	m ³ /h	4	4
R standard*	Q ₃ /Q ₁		160	160
Starting flow rate		l/h	0.6	0.6
Minimum flow rate*	Q ₁	l/h	25**	25**
Transitional flow rate*	Q ₂	l/h	40	40
Overload flow rate	Q ₄	m ³ /h	5	5
Head loss at Q ₃		bar	0.6	0.6
Kvs (deltaP=Q ² /Kvs ²)			4.69	4.69

* Other values on request

** Based on R 160

APPROVAL

ALTAIR MCI V5		
MID		LNE - 39018 Type A3
Standards		ISO 4064 OIML R49
Dynamic range (Q ₃ /Q ₁)	R	40 80 160
Potable water		ACS AoC DEU Belgaqua PZH WRAS

REACH

Information pursuant to Article 33 (1) of Regulation (EC) No 1907/2006 of the European Parliament and of the Council of 18 December 2006:

This product series contains components with the following substances in a concentration of more than 0.1% weight by weight (w/w):

- Lead (CAS no.: 7439-92-1)

TEMPERATURE AND PRESSURE

ALTAIR MCI V5		
Water temperature	°C	0.1 ... +50
Ambient temperature	°C	+1 ... +55
Ambient storage temperature	°C	-10 ... +55
Nominal pressure	bar	16

DIMENSIONS

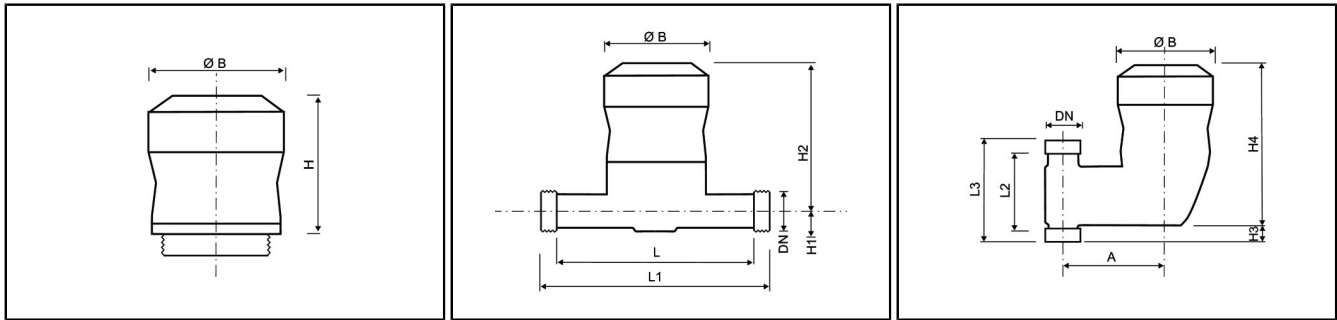

Housing			Horizontal	Rising Pipe
Nominal diameter	DN	mm	20	20
Permanent flow rate	Q ₃	m ³ /h	4	4
Length	L	mm	160	-
Overall length (DIN ISO 4064)	L1	mm	190	-
Length	L2	mm	-	75
Overall length rising pipe with thread	L3	mm	-	105
Connection thread on meter		inch	G1B	G1B
Height	H	mm	94	94
Height	H1	mm	23	-
Height	H2	mm	141	-
Height	H3	mm	-	28
Height	H4	mm	-	169
Diameter	Ø B	mm	93	93
Width	A	mm	-	95
Weight of capsule		kg	0.37	0.37
Weight of complete meter (horizontal)		kg	1.33	-
Weight of complete meter (rising pipe)		kg	-	1.75

PRECISION CURVE

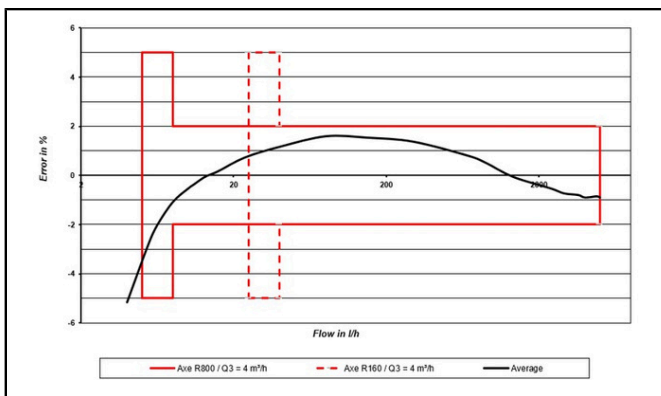

DN20 MCI

OPTIONS

Glass/metal copper register

Economic Actor Information

Applicable regulation and legal obligations for products may change.

DIEHL METERING monitors applicable regulation to ensure their products comply at the date of placing on the market.

Each economic actor making products available on the market thereafter must independently keep informed about the current applicable regulation.

For questions, please contact: metering-germany-info@diehl.com

Diehl Metering GmbH
Donaustraße 120
90451 Nürnberg
Germany
Phone: +49 911 6424-0
metering-germany-info@diehl.com
www.diehl.com/metering

**EMPOWER A
SUSTAINABLE
FUTURE**