

# IZAR IoT GATEWAY Premium

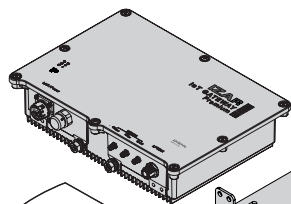

8x   
M6x10mm, type T30

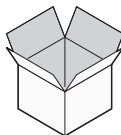

## Radio frequency 868 MHz

Funkfrequenz / Fréquence radio / radio frecuencia

### Frequency bands

Frequenzband /  
Bande de fréquence /  
Banda de frecuencia

- LTE-FDD: B1/B2/B3/B4/B5/B7/B8/B12/B13/B18/B19/B20/B25/B26/B28
- LTE-TDD: B38/B39/B40/B41
- WCDMA: B1/B2/B4/B5/B6/B8/B19
- LoRa: EU863-870 MHz
- mioty®: 868-870 MHz (EU0 and EU1 band)
- wM-Bus: 868-870 MHz

LPWAN antenna gain max. 15.3 dBi

max. LPWAN Antennengewinn /  
Gain d'antenne LPWAN max. /  
max. ganancia de antena LPWAN



Cellular antenna gain max. 3.5 dBi

max. Mobilfunkantennengewinn /  
Gain d'antenne cellulaire max. /  
max. ganancia de antena celular

Connection 1x N (LPWAN),  
3x SMA (2x LTE, 1x GNSS)

Anschluss / Connexion / Conexión

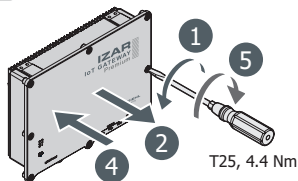

15 mm

25 mm

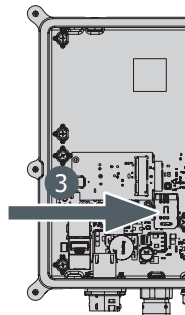

# IZAR IoT GATEWAY Premium



User guide

5 

URL

4

Status indicator

-  Activity
-  Status
-  Power

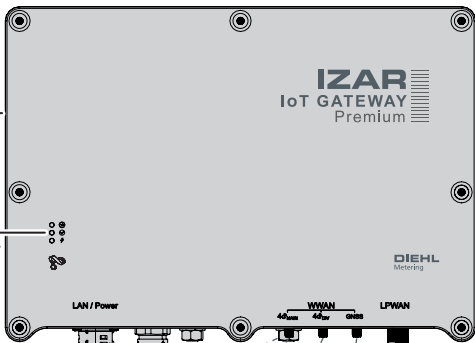

1 LAN/Power

Accessory:  
PoE++ injector or  
PoE++ suitable LAN cable

GND 

4G<sub>MAIN</sub>

4G<sub>DIV</sub>

GNSS

2 

LoRaWAN®   
network

M-Bus   
WIRELESS 3

mioty®   
network



6 URL

7 **Login:** admin  
**Password:** admin-<M-number>

8 License key from supplier/  
Lizenzschlüssel des Versorgers/  
Clé de licence du fournisseur/  
Clave de licencia del proveedor

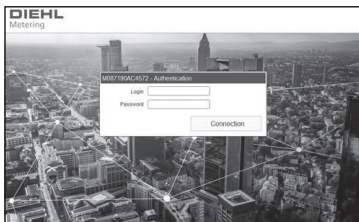

**i**

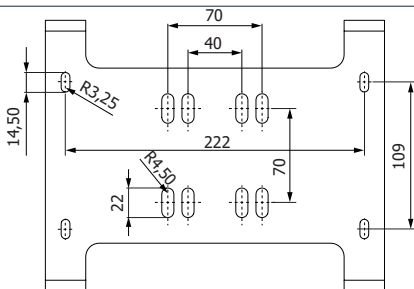

## Mast mount / Mastmontage / Fixation sur mât / Montaje en pértiga

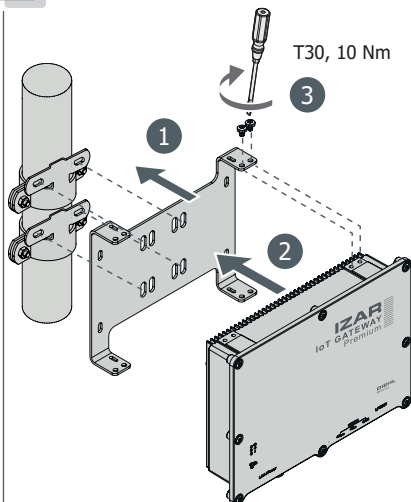

T30, 10 Nm

3

1

2

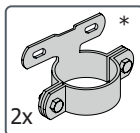

\* not included /  
nicht enthalten /  
non inclus /  
no se incluye



Use only the included screws. /  
Nur die mitgelieferten Schrauben  
verwenden. /  
Utiliser uniquement les vis fournies. /  
Utilice sólo los tornillos incluidos.

No dirt, oil,... on screws. /  
Kein Staub, Öl,... auf Schrauben. /  
Pas de saleté, d'huile,... sur les vis. /  
Sin suciedad, aceite,... en los tornillos.

No multiple use of these screws. / Keine Mehrfachverwendung dieser Schrauben. /  
Pas d'utilisation multiple de ces vis. / No se permite el uso múltiple de estos tornillos.

Use screw locking (PRECOTE 80-8 red is advised). /  
Schraubensicherung verwenden (PRECOTE 80-8 red wird empfohlen). /  
Utiliser la vis de blocage (PRECOTE 80-8 red est recommandé). /  
Utilizar tornillo de bloqueo (se aconseja PRECOTE 80-8 red).



## Wall mount / Wandmontage / Fixation murale / Montaje en pared



Keep clearance above and below the Gateway! /  
Auf Freiraum oberhalb und unterhalb des Gate-  
way achten! /

Gardez un espace libre au-dessus et en  
dessous du Gateway! /

¡Mantener la distancia encima y debajo del  
Gateway!

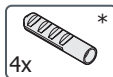

\* not included /  
nicht enthalten /  
non inclus /  
no se incluye

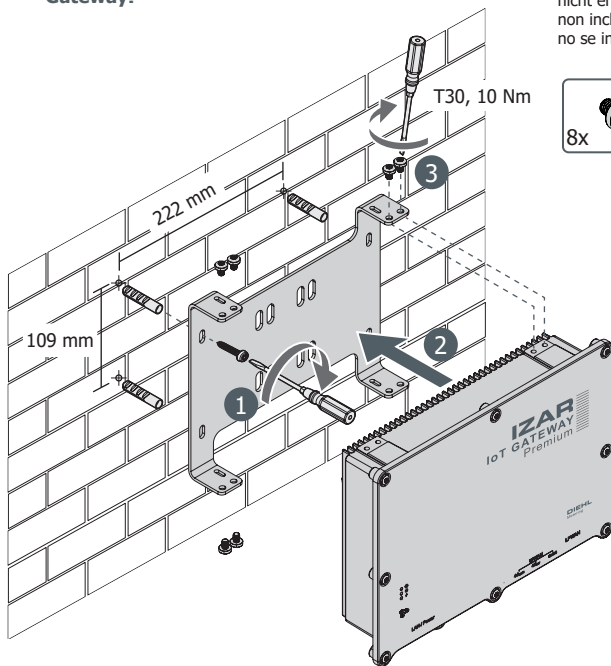



Operation conditions / Betriebsbedingungen /  
Conditions d'utilisation / Condiciones de manejo

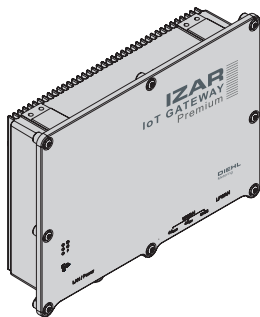

## TX-power

### mioty®

869.525 MHz (EN 300220-2, Band P)  
500 mW e.r.p. ≤ 10 % duty cycle

### LoRa®

865.000 MHz (EN 300220-2, Band L)  
25 mW e.r.p. ≤ 1 % duty cycle

868.000 MHz (EN 300220-2, Band M)  
25 mW e.r.p. ≤ 1 % duty cycle

869.400 MHz (EN 300220-2, Band P)  
500 mW e.r.p. ≤ 10 % duty cycle

### Cellular

Class 3 (23 dBm ±2 dB) for LTE FDD bands

Class 3 (23 dBm ±2 dB) for LTE TDD bands

Class 3 (24 dBm +1/-3 dB) for WCDMA bands



## Simplified EU declaration of conformity

Hereby, Diehl Metering declares that the radio equipment type described in this manual is in compliance with Directive 2014/53/EU.

The full text of the EU declaration of conformity is available at the following internet address: <https://www.diehl.com/metering/en/support-center/download-center/>

Hiermit erklärt Diehl Metering, dass der in dieser Bedienungsanleitung beschriebene Funktyp mit der Richtlinie 2014/53/EU konform ist.

Der vollständige Text der EU-Konformitätserklärung ist unter der folgenden Internetadresse verfügbar: <https://www.diehl.com/metering/de/support-center/download-center/>

Par la présente, Diehl Metering déclare que le type d'équipement radio décrit dans ce manuel est conforme à la directive 2014/53/UE :

Le texte intégral des déclarations de conformité de l'UE est disponible à l'adresse internet suivante : <https://www.diehl.com/metering/fr/assistance/centre-de-téléchargement/>

Por la presente, Diehl Metering declara que el tipo de equipo de radio descrito en este manual cumple la Directiva 2014/53/UE.

El texto completo de la declaración de conformidad de la UE está disponible en la siguiente dirección de Internet:

<https://www.diehl.com/metering/es/centro-de-servicio-tecnico/download-center/>

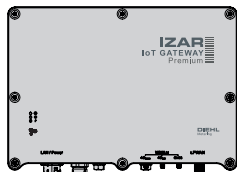

## IZAR IoT GATEWAY Premium



Access to the user guide via our online customer portal.

Bedienungsanleitung zugänglich im Internet-Kundenportal.

L'accès au guide d'utilisateur se fait via le portail client en ligne.

Acceso a la guía de usuario a través de nuestro customer portal en línea.