

Dimension "X±0,2"	Dimension "Y±0,05"	Dimension "Z"	Dimension "L"
5,85	10,5	2,4	16,35
5,85	11,5	2,4	17,35

Plating variants
Press-fit zone
Ni 1 - 3µm, Sn mt 0,3 - 1,1µm
Ni 1 - 3µm, Adv. Indium 0,3 - 1,1µm
Ni 1,3 - 2,2µm, Adv. AgSn 0,35 - 0,75µm

Platin variants
Connector side
Ni 1,0 - 2,2µm, Sn mt 1 - 3µm
Ni 1,0 - 3,0µm, Ag 1,5 - 5,0µm *2
Ni 1,0 - 2,2µm, Au 0,8 - 2,0µm *1

*1 (AuCo - alloy (hard gold) with 0,2 - 0,3%Co)

*2 (fine silver with 75 - 95HV and Thiol passivation) (02)

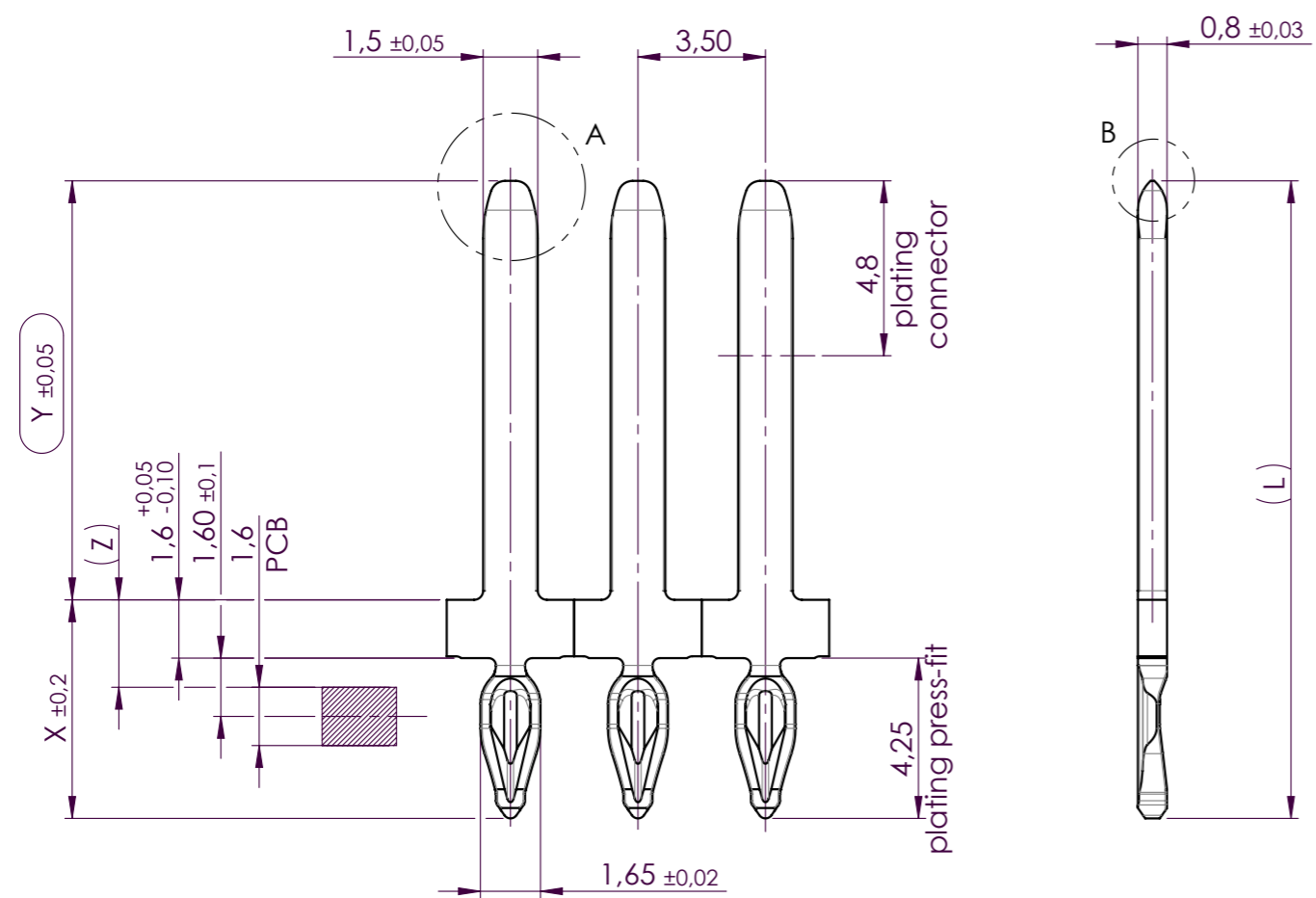

Delivery condition

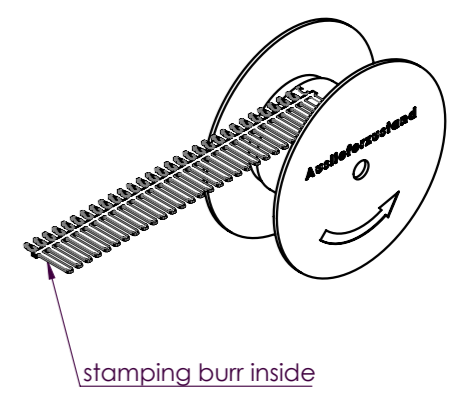

- Press-fit zone according to DMA-drawing 80991
- Product drawing 81018

Schutzvermerk nach DIN 34 / ISO 16016 beachten

Erstellt in: SOLIDWORKS	Toleranzen DIN ISO 2768-m	Maßstab 5:1	Material CuNiSi (C70250) R620	Pos. Nr.	
	nicht bemaßte Konturen siehe 3D-Datensatz	Benennung Marketingzeichnung DMA-Katalog	Stk.		
	Datum 11.01.2021	Name Krause	Kontaktstift 1,5 x 0,8 Contact Pin 1,5 x 0,8		
	Gepr	Norm			
02	"Thiol passivation" hinzu	18.01.2023	Krause	Zeichn.-Nr. 81017 - 02	Blatt-Nr. .
01	4,25 war 4,40	21.01.2021	Krause		
Zust	Änderung	Datum	Name	Auftr.-Nr.	BI-Format A3